



NORTHERN TRANSFORMER

INCORPORATED

ONAN SEALED TRANSFORMER

SERIAL No. DATE OF MFR.

KVA 3 PHASE 60 Hz
 IMPEDANCE PERCENT AT ° C

CORE & WINDINGS KGS

TANK & FITTINGS KGS

OIL 1768 LITRES KGS

TOTAL MASS KGS

SUITABLE FOR ONAF RATING OF KVA

RATING AT AMBIENT OF 0°C KVA

VOLTS	TAP POSN	AMP	BETWEEN	VOLTS	AMP	BETWEEN
46200	1	12.5				
45100	2	12.8				
44000	3	13.1	H1 H2 H3	600	962	X1 X2 X3
42900	4	13.5				
41800	5	13.8				

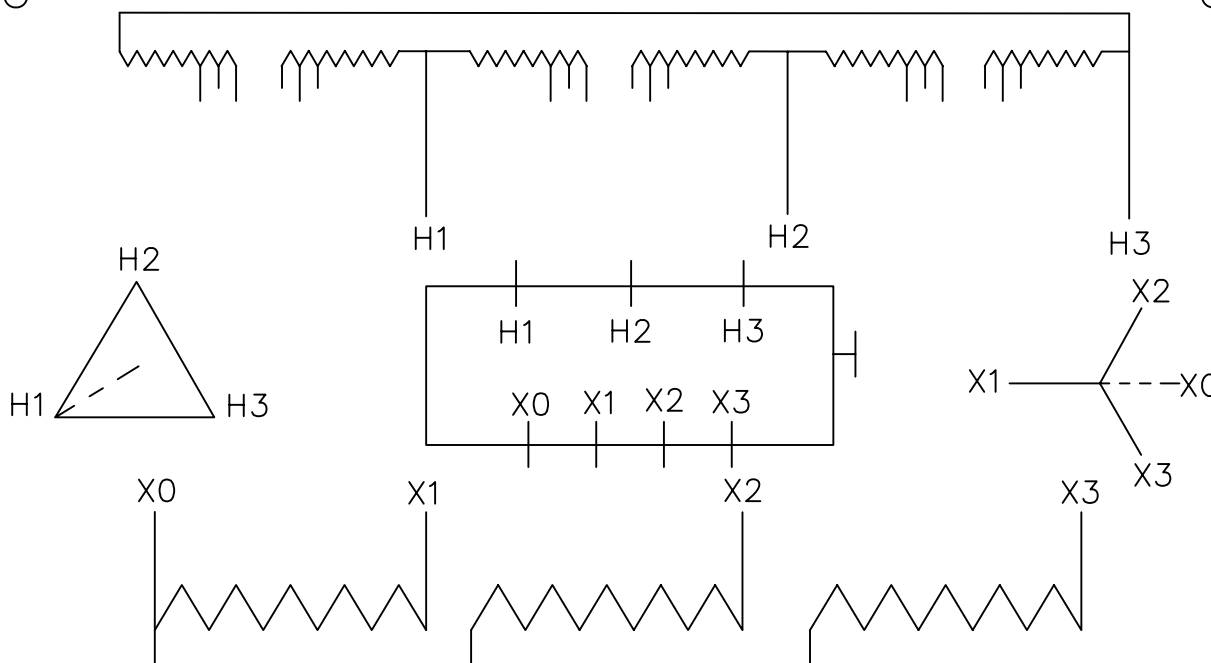

CAUTION: DO NOT OPERATE TAP SWITCH WITH TRANSFORMER ENERGIZED

SPECIFICATION CSA C88-M90 & C802.3-01			
INSULATION LEVEL	HV 250 KV	LV 30 KV	
MAXIMUM TEMPERATURE RISE	65°C		
WINDING MATERIAL	COPPER		
TANK PRESSURE	+8 PSI / -14.7 PSI / +55 kPa / -101kPa		
PURCHASER'S SERIAL No.	PO-04401		

BUILT TO TAMPER RESISTANT REQUIREMENTS OF CSA C227

DESIGN IMPEDANCE: 6.0 %

NOTE: TEST IMPEDANCE WILL
BE ON NAMEPLATE

MATERIAL - .032 ANNOXIDIZED ALUMINUM
7 X 13

REV.	REMARKS	BY:	DATE:
Northern Transformer INCORPORATED			
PLOT 1=1	DRAWN BY: KENDRA WATKINS	DATE: OCT 29/07	REV. 0
JOB:	CHECKED BY:	DATE:	S.O. NO 06-2184
TITLE: NAMEPLATE			
WHITBY HYDRO			DRAWING NO. 2184-020B